

Installation Instructions

PROBLEM	POSSIBLE CAUSE	SUGGESTED ACTION
Water too hot.	Temperature control is not correctly commissioned.	Adjust the temperature control - this is only a job for a suitably qualified person.
	Not enough cold water flowing through shower.	Turn temperature control anti-clockwise.
	Increase in the ambient cold water temperature.	Turn temperature control anti-clockwise.
	Cold water supply blocked.	Turn off shower and consult a competent plumber.
	High volume of cold water drawn off elsewhere.	Reduce the simultaneous demand from the supply.
	Cold water filter blocked.	Remove valve and clean filters.
Water too cold.	Temperature control is correctly commissioned.	Adjust temperature control.
	Not enough hot water flowing through shower.	Turn the temperature control clockwise.
	Decrease in the ambient cold water temperature.	Turn the temperature control clockwise.
	Hot water filter blocked.	Remove valve and clean filters on the inlet.
	Insufficient hot water supplies from the heating system.	Make sure the hot water is available by trying a hot water tap elsewhere in the house.
	Hot water supply blocked or restricted.	Turn off shower and consult a suitably competent plumber.
	Pressure in excess of max recommended.	Fit pressure reducing valve.
Water does not flow or shower pattern collapses when another outlet is turned on.	Water supplies cut off	Check elsewhere in house and if necessary contact local water company.
	Blockage in pipework.	Turn off shower and consult a suitably competent plumber.
	Valve filters blocked by debris in water supply.	Remove valve and clean filters.
	Showerhead blocked.	Clean Showerhead.
	System not capable of supplying multiple outlet at the same time.	Reduce simultaneous demand. Check stop/service valves are fully open. Check if enough water pressure.
Shower controls noisy whilst in use.	Running pressure in excess of maximum recommended.	Fit reducing disc to outlet of valve.
Shower will not shut off.	Flow control cartridge worn.	Renew flow control cartridge see parts list.



Thermostatic Mixer Valve with Overhead



Thermostatic Mixer Valve with Riser Rail

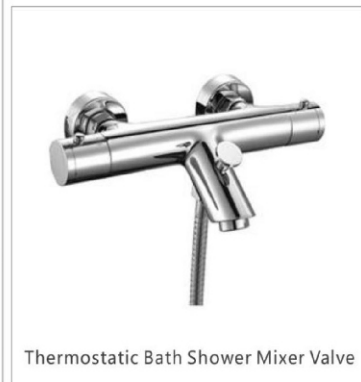

Thermostatic Bath Shower Mixer Valve

GENERAL INTRODUCTION

Please read these instructions thoroughly and retain for future use.

The plumbing installation of this shower must comply with the requirements of UK

Water Regulations/Bylaws (Scotland), Building Regulations or any other regulations specified by the local Water Authority and supplier.

We strongly recommend that you use a plumber registered with or a member of an Association:

Institute of Plumbing (IOP) - throughout the UK
National Association of Plumbing, Heating and Mechanical Services Contractors (NAPH & MSC) - England & Wales
Water Industry Approved Plumber Scheme (WIAPS)

SAFETY WARNINGS

Layout and sizing of pipework must be such that when other services are used, pressures at the shower control inlets do not fall below the recommended minimum.

DO NOT choose a position where the shower could become frozen.

DO NOT connect this mixer valve to any form of tap or fitting not recommended by the manufacturer.

The shower handset must be regularly cleaned to remove scale and debris.

Conveniently situated service valves in each inlet supply must be fitted as an independent method of isolating the shower should maintenance or servicing be necessary, these valves should not restrict the flow.

DO NOT operate the shower outside the guidelines as laid out in 'site Requirements'.

Cleaning the filters

It is advised that this should be carried out by a qualified person.

Turn off the water supplies before starting.

To gain access to the filters remove the unit from the inlet fittings.

Remove the circlip and then the filter.

Wash the filters thoroughly under running water, use a suitable brush to remove all debris.

Reassemble and fit in reverse order.

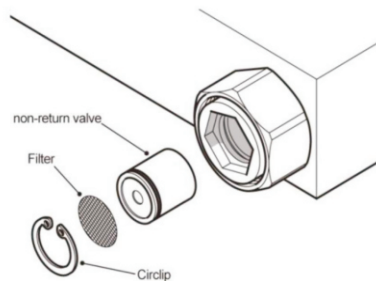

Disinfection

Where chlorine is used for the disinfection of water systems all relevant guidelines and approved codes of practice must be strictly followed. Failure to comply with the relevant guidelines and approved codes of practice may invalidate your guarantee.

MAINTENANCE

The following maintenance procedure must be carried out for commercial and health care premises, but is not necessarily required for domestic installations.

Maintenance of the unit is required to give continued performance after installation and that it continues to provide scald prevention.

Note: a thermostatic mixing valve in need of maintenance can be undetectable in normal use and only becomes apparent when a disruption occurs in the hot or cold water supply temperatures or pressures.

Initially check the filters for debris once every three months and clean if necessary.

Perform a thermal shut off test every three months, and check the maximum temperature setting. See the 'Commissioning' section for the details of this test and readjustment of the maximum temperature setting if required.

If the maximum water temperature varies by more than 2°C from the commissioned setting then carry out the following checks

Check the isolating valves are fully open.

Check the internal surface for scaling.

If the body requires descaling then it should be removed from the pipework to carry this work out (all rubber parts MUST be removed before descaling).

Check the function of the non-return valves. The non-return valves (NRVs) prevent cross-flow between hot and cold supplies under unequal pressure conditions. They are designed for long life with no maintenance.

Note: the (NRV's) will only operate in one direction - water should be able to flow into the unit from the inlets, but NOT back out through the inlets.

If these checks do not highlight the reason for the temperature variation, then internal components will require replacement - please see the spare parts list.

Cleaning

It is recommended that all products are cleaned using warm, soapy water.

Do not use abrasive or aggressive chemical cleaning products as this may affect the product surface finish and invalidate your guarantee.

SITE REQUIREMENTS

The installation must be in accordance with Water Regulations Advisory Service (www.wras.co.uk).

Water pressure requirements

Minimum running water pressure: 0.1 bar, but will operate better at a minimum of 0.5 bar.

Maximum running water pressure: 5 bar. Maximum static water pressure: 10 bar.

Water minimum flow rate

For your shower to perform well you should ensure that the pressure is as specified and a minimum flow of 5 liters per minute is available at both hot and cold inlets.

WATER TEMPERATURE REQUIREMENTS

Maximum hot water temperature = 80°C, Recommended maximum = 65°C.

Minimum hot water temperature = 55°C, Maximum cold water temperature = 20°C.

BS 6700 recommends that the temperature of stored water should never exceed 65°C.

TEMPERATURE ADJUSTMENT RANGE

The mixed water temperature can be adjusted from cold through to hot. There is a safety stop preset at a set temperature of about 38°C.

In the event of failure of cold water system, the mixer valve automatically reduces the flow of hot water to prevent scalding. It will only operate again once the flow of cold water has been resumed.

INSTALLATION

Before proceeding with the installation check all the components in the component list are present.

WARNING!

The shower must not be positioned where it will be subject to freezing conditions.

The mixer valve should be fitted only after all the pipework has been installed.

Do not use jointing compounds on any of the pipe fittings. Do not solder fittings near the mixer valve as heat can damage the valves seals. Always flush the system prior to installing the valve.

Before installing, make sure the mixer valve is kept in a clean place to prevent any rubbish etc. getting into the openings while fitting the pipework.

The mixer valve is suitable for installation on a solid wall, a stud partition wall, dry lined wall or fixing to a cubicle or panel.

The water pipes should be securely attached within the wall or panel to support the mixer valve and prevent movement or water noise after installation.

The mixer valve hot water inlet has a red symbol next to the inlet and must be on the left hand side. If the mixer valve you are fitting is with a riser rail the outlet should point down.

The mixer valve is designed to work at the same hot and cold water pressures. If this is not the case a flow controller (disc with small holes) can be fitted to the higher pressure supply to the valve. This is best done by testing each one to find out which gives the best results.

Before starting the mixer installation, make sure all the openings on the valve are carefully covered to stop ingress of any debris, etc. while routing the supply pipework.

SPARE PARTS

Thermostatic Mixer Valve

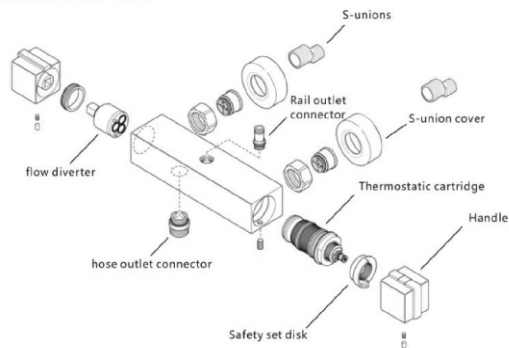

Thermostatic Bath Mixer Valve

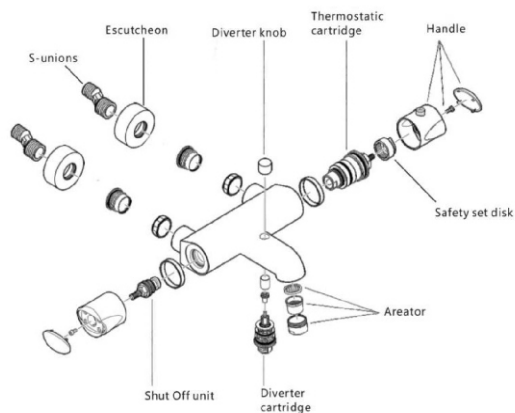

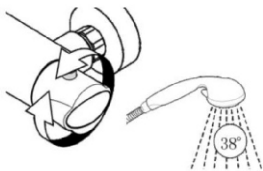

fig.10

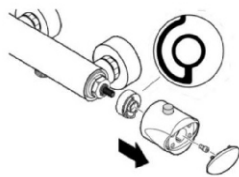

fig.11

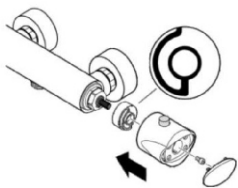

fig.12

APPROVALS

This mixer valve has been designed to comply with the requirements of:

BSEN1111
BSEN1287
WRAS

FLOW CHART

Thermostatic Mixer Valve with Riser Rail

Flow Rate (l/m)	6.0	9.5	12.5	16.5	18.0
Pressure (bar)	0.2	0.5	1.0	2.0	3.0

Thermostatic Mixer Valve with Overhead

Flow Rate (l/m)	4.0	6.3	9.5	13.5	16.2
Pressure (bar)	0.2	0.5	1.0	2.0	3.0

Conditions for test

Inlet temperatures comply with EN1111 requirements
Outlet temperature 38°C
Flow Control Fully Open
Open Outlet - No hose or showerhead connected

Hard water areas

If it is intended to operate the shower in areas of hard water (above 200-ppm temporary hardness), a scale inhibitor may have to be fitted.

For best performance the showerhead **MUST** be regularly cleaned to remove scale and debris.

WATER SYSTEM REQUIREMENTS

This mixer shower is suitable for:

- Pumped gravity systems.
- Fully modulating type combination boilers.
- Multi-point hot water heaters.
- Thermal storage.
- Unvented systems.

When installing this mixer with a Combination or multi-point boiler, it may be necessary to install flow regulation.

Check that the appliance is capable of delivering hot water at a minimum switch-on flow rate of 3 litres per minute. At flow rates between 3 and 8 litres per minute, the appliance must be capable of raising the water temperature to 52°C (minimum).

The pressure at both the hot and cold water supplies to the mixer valve should be the same, and the installer should ensure that the flow is not affected by other taps elsewhere in the house. It is very important that for use in any mains pressure systems an expansion tank and a pressure reducing valve has been fitted to ensure the pressure does not exceed 5 Bar. This should be confirmed by the installation engineer or competent person before installation.

Water temperature at the inlet of the mixer valve must remain relatively constant when flow rate adjustments are made (refer to the appliance-operating manual to confirm compatibility with this mixer shower).

Where thermal store systems and instantaneous gas water heaters are used, if excessive draw-off take place the appliance may not be able to maintain an adequate output temperature. This could result in the shower temperature becoming noticeably cooler.

Note: On sites where the running pressure is above 5 bar, the use of a suitably sized pressure reducing valve fitted in the COLD mains supply pipework can provide nominally equal pressures at the mixer Shower.

DO NOT connect the mixer shower to a gravity HOT supply and a mains COLD supply (or vice versa).

The pipework should be installed such that the flow is not significantly affected by other taps and appliances being operated elsewhere on the premises.

TYPICAL SUITABLE INSTALLATIONS

Instantaneous Gas-heated Systems, e.g. Combination Boilers(Fig.1)

The shower control MUST be installed with a multipoint gas water heater or combination boiler of a fully modulating design (i.e. to maintain relatively stable HOT water temperatures).

A drop tight pressure reducing valve MUST be fitted if the supply pressures exceed 5 bar running.

An expansion vessel (shown in fig.3) MUST be fitted, and regularly maintained, to make sure the shower mixer is not damaged by excess pressures. This may already be installed within the boiler (check with manufacturer) and in addition to the normally larger central heating expansion vessel.

The layout and sizing of pipework MUST be such that nominally equal inlet supply pressures are achieved and the effects of other draw-offs are minimised. The HOT supply temperature MUST remain a minimum of 10°C hotter than the required blend temperature for optimum performance.

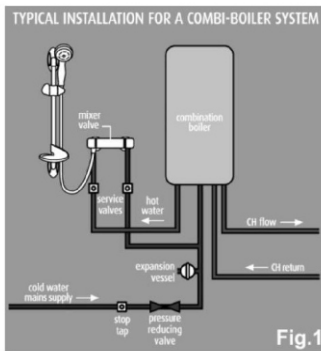

FITTING THE DOUBLE INTERLOCK HOSE AND HANDSET

Connect one end of the double interlock hose to the outlet on the mixer valve, making sure that the sealing washer is in place.

Screw the remaining end of the double interlock hose to the handset, then locate the handset into the handset height adjuster making sure the sealing washer is in place. Carry out a leak test.

NOTE: It is the conical end of the double interlock hose which grips into the handset height adjuster. The handset will not fit in the height adjuster without the double interlock hose attached.

The handset height adjuster grips the conical nut on the double interlock hose.

FITTING THE LARGE FIXED SHOWERHEAD FOR

Screw the large fixed showerhead to the overhead assembly. Make sure the sealing washer is in place and screw tight to seal the joint.

TEMPERATURE ADJUSTMENT RANGE

The mixed water temperature can be adjusted from cold through to a top limit (which can be pre-set during installation – factory set at approximately 38°C) with full anti-scald protection throughout the range.

TEMPERATURE ADJUSTMENT RANGE

The mixed water temperature can be adjusted from cold through to a top limit (which can be pre-set during installation – factory set at approximately 38°C) with full anti-scald protection throughout the range.

Calibrating Thermostatic Valve

If the temperature reading is different to the showering temperature, turn the thermostat handle until a 38°C reading is shown on your thermometer (fig.10).

Remove the handle end cap, undo the screw and pull off the handle and safety set disk (fig.11).

Refit the safety set disk as shown. Rotate the handle so the button is positioned at 12 o'clock and re-fit onto the spindle. Replace the screw and end cap (fig.12)

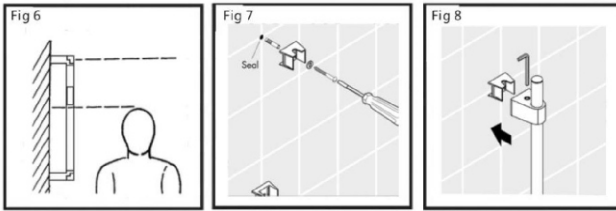

FITTING THE VERTICAL RAIL ASSEMBLY TO MIXER VALVE

Slide the height adjuster on to the vertical rail and lock in place.

NOTE: Ensure you have the correct valve with the vertical rail water outlet on the top and the threaded outlet facing down when the hot water inlet is to the left.

Attach the vertical rail to the valve (Fig. 9). Then mark the position for the vertical rail bracket.

NOTE: Ensure the rail is vertically above the valve using a spirit level.

Ensure there are no cables or pipework behind the wall bracket position. Remove the vertical rail and position the wall bracket in the marked position. Mark the 2 hole positions for the screws. Drill and plug the wall. (The wall plugs are suitable for most brick walls - use an appropriate masonry drill. If the wall is plasterboard or a soft building block, use suitable wall fixings and a drill bit, not supplied).

Secure vertical rail bracket to wall using the pre drilled holes.

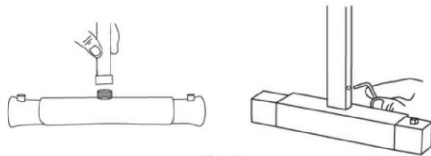

Fig. 9

Unvented Mains Pressure Systems(Fig.2)

The shower control can be installed within unvented, stored HOT water cylinder.

For systems with no COLD water take off after the appliance reducing valve, it will be necessary to fit an additional drop tight pressure reducing valve when the mains pressure is over 5 bar. The drop tight pressure reducing valve must be set at the same value as the unvented package pressure reducing valve.

Note: An additional expansion vessel(Fig.4) may be required if a second pressure reducing valve is installed. This does not apply to packages with a COLD take off after the pressure reducing valve to the cylinder.

The layout and sizing of pipework MUST be such that nominally equal inlet supply pressures are achieved and the effects of other draw-offs are minimised.

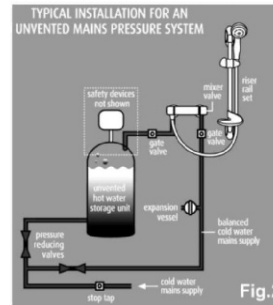

Fig.2

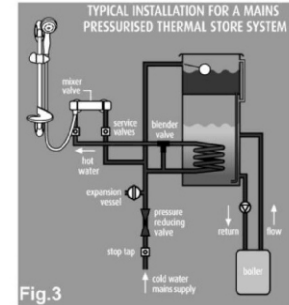

Fig.3

Mains Pressurised Thermal Store Systems(Fig.3)

Packages of this type, fitted with a tempering valve (blender valve) can be used. A drop tight pressure reducing valve MUST be fitted if the supply pressures exceed 5 bar running.

An expansion vessel (shown in fig.5) MUST be fitted, and regularly maintained, to make sure the unit is not damaged by excess pressures. This may already be installed externally or internally within the thermal store (Check with thermal store manufacturer).

Gravity Fed Systems (Fig.4)

The shower control MUST be fed from a COLD water cistern and hot water cylinder providing nominally equal pressures. There must be a minimum head of water of 1 metre. The minimum head distance is measured from the base of the COLD water cistern to top of the shower head.

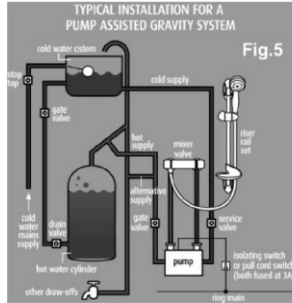
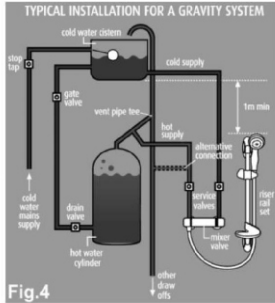

Pump assisted gravity fed systems(Fig. 5)

The pump MUST be fed from a COLD water cistern and hot water cylinder providing nominally equal pressures. The pump must be capable of maintaining a minimum running pressure of 1 bar.

SITING OF THE MIXER VALVE

Position the mixer valve so that all controls can be comfortably reached while using the shower.

SITING OF THE SHOWER

Having established the position of the mixer valve so that all controls can be comfortably reached whilst using the shower, the handset and riser rail can be positioned either side of the valve. Make sure any cables and pipework are not behind the required screw holes.

There is one option available with this mixer valve:

- Bar valve with Riser Rail
- Bar valve with Overhead

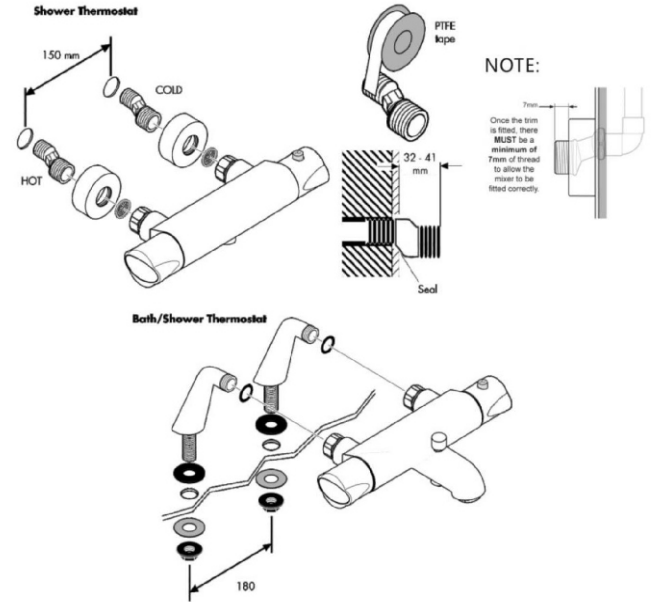

FITTING THE RISER RAIL

Having established the position of the mixer valve so that all controls can be comfortably reached whilst using the shower, the handset can be positioned either side of the riser rail (See Fig 6). Make sure any cables and pipework are not behind the required screw holes.

Remove wall bracket support from the riser rail wall brackets, mark the position of the holes and drill, plug and screw to fit the two wall brackets. Fix lower bracket to wall (See Fig 7 & 8).

FITTING OF THE MIXER VALVE

Shower Thermostatic Mixer Valve

The hot and cold water outlets should be 150mm apart (plus or minus 12mm). Hot on the left and cold on the right. The recommended plumbing fittings are ½" back plate elbows (not supplied).

Flush through the hot and cold water supplies.

Wrap PTFE tape round the S-unions and screw into the backplate elbows. The S-unions must protrude beyond the tiled surface between 32 and 41mm.

Seal the gap between the S-unions and the tiles.

Screw the escutcheons onto the S-unions.

Fasten the thermostatic mixer onto the S-unions using the union nuts. Align the unit and tighten the nuts (be careful not to damage the chrome finish). The S-unions allow inaccuracies to be compensated for.

Bath/Shower Thermostatic Mixer Valve

Two options

A. Wall mounted

B. Fitting to the bath using the supplied pillar unions.

The pillar unions are designed to fit tap holes on a bath 180mm apart with hot on the left and cold on the right.

Place fibre washers into the holes of the chrome union nuts. (DO NOT USE FILTERS WHEN USING PILLAR UNIONS!) From under the bath fit a large seal washer over the thread then fix with the nuts.

Fasten the mixer onto the union pillars using the union nuts (be careful not to damage the chrome finish).

Consult the illustration below to make sure you check from the component list that all the parts for your system are supplied.

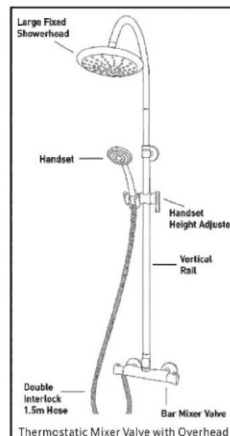
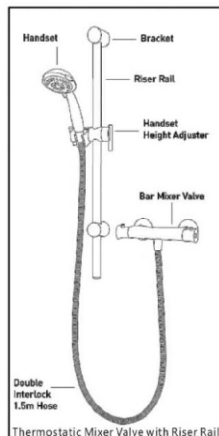
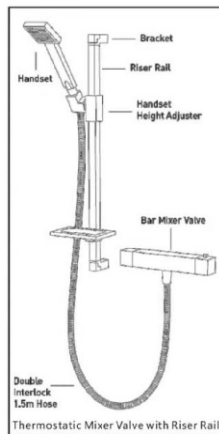

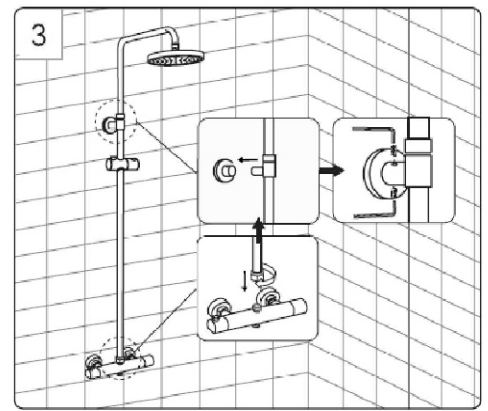
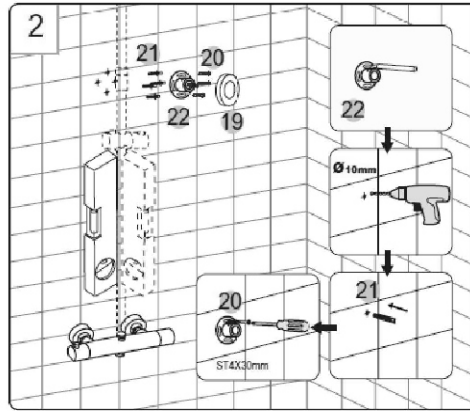
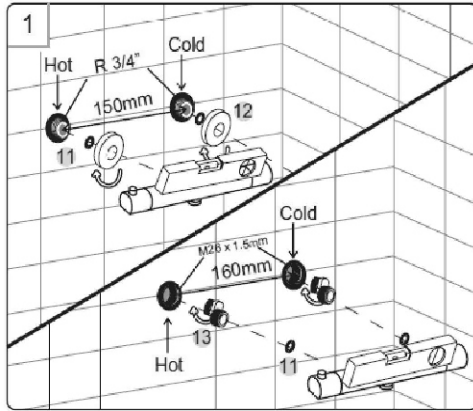

Step by Step Installation!

1. Valve, 2. Rail, 3. Wall bracket, 4. Shower head, 5. Handset, 6. Adjustable rail

